



# Systems and Components

## Contents

- Examples of System Configurations ..... 332-335
  - Isocratic LPLC Process System EEx IIC T4
  - Quaternary HPLC System with Injection Module
  - Tertiary MPLC System for universal DNA purification
  - Binary HPLC System with Automatic Sample Injection
- Liquid Chromatography Components..... 336-337
- K-Prep Series .....338
- Bio-Prep Series .....339

## Introduction

### Kronlab Custom Made Systems

The production programme of the Kronlab division of the business traditionally includes components and systems especially for preparative liquid chromatography, glass columns, pumps and valves. What is more, we have basic contracts with numerous prominent companies for the OEM manufacture of HPLC system components and their associated technology, for example for liquid handling applications or for building tailor-made equipment. Valveless reciprocating rotation pumps, manual and motor valves, fittings and connectors are manufactured here, as well as tubing being produced and stored.



# Isocratic LPLC Process System EEx II C T4

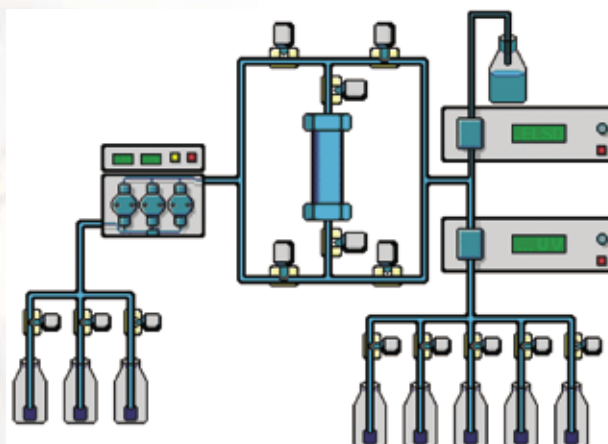

## Basic Specifications

- 830-8300 ml/min at 6 bar, 3-head membrane pump
- explosion proof to EEx II C T4
- choice of eluents
- UV detection (light conduction technology) and ELSD (Split)
- back-flush / bypass facility
- fractionating valves
- DAC column 500 mm i.d., bed height max. 1000 mm, YMC Silica 50  $\mu$ m spherical
- mobile system, manual control

# Quaternary HPLC System with Injection Module

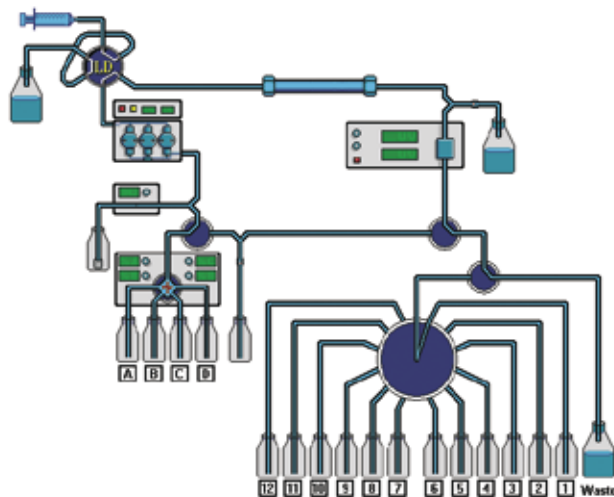

## Basic Specifications

- 2-1000 ml/min at 140 bar, triple reciprocating pump
- quaternary low-pressure mixing
- pumped injection module
- 100 mm i.d. compressed bed column, NP/RP separations
- 2 channel UV detection
- peak recycling facility
- fractionating valves
- software control with peak detection
- mobile system

# Tertiary MPLC System for universal DNA purification

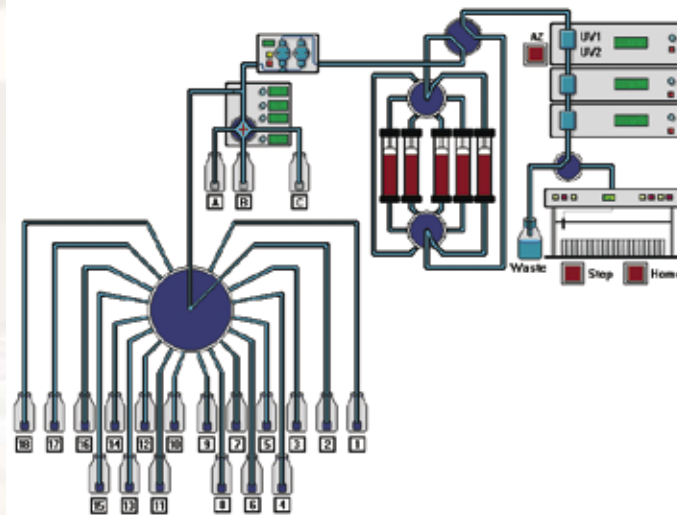

## Basic Specifications

- 0.2-100 ml/min at 25 bar, double reciprocating pump
- tertiary low pressure mixing
- choice of samples and columns
- accompanying affinity columns
- UV, pH, and conductivity detection
- software control with peak detection

# Binary HPLC System with automatic Sample Injection

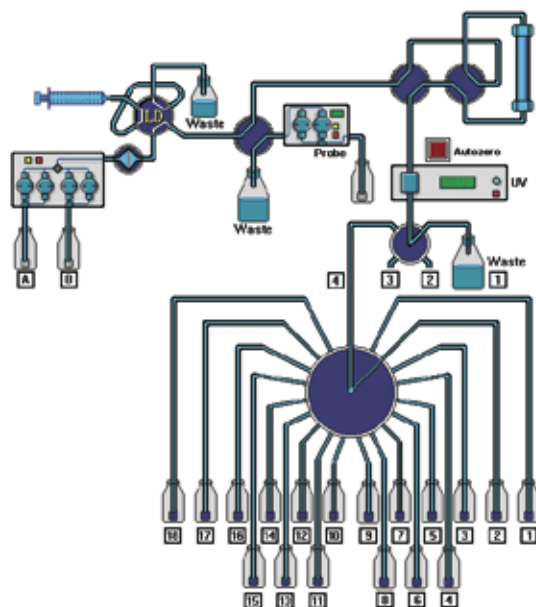

## Basic Specifications

- 1-500 ml/min at 150 bar, double reciprocating pump
- binary high pressure mixing
- separate pump injection
- various HPLC columns and ECO<sup>PLUS</sup> 50 mm i.d. glass columns
- single channel UV detection
- fractionating valves
- software control with peak detection
- mobile system

# Liquid Chromatography Components

## The HPLC solvent pump

Dual plungers and a high precision motor allow highly accurate pumping with minimal pulsation.

Key features include:

- a wide range of flow rate: the minimum flow rate is precisely 1/1000 of the maximum
- gradient operation: addition of a sub-pump enables gradient operation
- recycle compatibility: dead volume is extremely low so that the peak recycling characteristics are outstanding
- self-wash (optional): cleaning fluid is pumped through the plunger wash ports to provide cleaning of corrosive substances such as salts
- explosion proof (optional): explosion proof pumps are available
- high flow capabilities: flow rates of 3 l, 5 l and over 10 l/min are also available



K-100

### Standard Specifications

	K-100	K-300
<b>Flow rate range</b>	0.1 - 100 ml/min	0.3 - 300 ml/min
<b>Pressure limit</b>	200 bar	100 bar
<b>Pumping mechanism</b>	double plunger, linear cam driven	
<b>Pumping method</b>	constant flow	
<b>Tubing connections</b>	SS316, zirconia, reinforced Teflon, PEEK, ruby, sapphire	
<b>Power requirement</b>	AC100 (AC-200) 50-60 Hz 0.6 kW	
<b>Dimension</b>	225 (W) x 485 (D) x 205 (H) mm	



K-1000

### Standard Specifications

	K-500	K-1000
<b>Flow rate range</b>	0.5 - 500 ml/min	1 - 1000 ml/min
<b>Pressure limit</b>	100 bar	100 bar
<b>Pumping mechanism</b>	double plunger, linear cam driven	
<b>Pumping method</b>	constant flow	
<b>Tubing connections</b>	SS316, zirconia, reinforced Teflon, PEEK, ruby, sapphire	
<b>Power requirement</b>	AC100 (AC-200) 50-60 Hz 0.6 kW	
<b>Dimension</b>	380 (W) x 550 (D) x 220 (H) mm	

# Liquid Chromatography Components

## Auto-injector

An easy to use automated syringe type injector!

A practical alternative to injection using piston pumps.

Key features include:

- excellent for repetitive stacking of injections
- operation is controlled by internal computer
- 10 ml or 5 ml syringes can be used
- remote control can be conducted from an external equipment
- the syringe does not contact the sample so that cleaning is unnecessary



## Standard Specifications

	IS-50	IS-100
<b>Sample loop</b>	50 ml	100 ml
<b>Dimensions of the syringe</b>	25 ml (reciprocating for over 25 ml)	
<b>Syringe drive</b>	stepper-motor	
<b>Oscillator</b>	SS316, PTFE	
<b>Valve pressure limit</b>	100 bar	
<b>Connection tube</b>	1/16 inch	1/8 inch
<b>Minimum injection mass</b>	syringe 1/10 (or 1 ml)	

# Preparative LC-Systems

## K-Prep Series

Our fully automated preparative liquid chromatography systems are ideal for the isolation and purification of high-value substances such as drugs (API), additives, and fine-chemical products.

Systems are available for purifications from lab through pilot to production-scale.

System features:

- fully automated continuous operation capability via computer control
- interactive interface
- precise and fast isolation by isocratic or gradient elution chromatography
- compactness for portability and simplicity
- provision of security features
- designed for easy maintenance
- easily expandable instrumentation
- compatibility with GLP/GMP validation
- numerous options including column backflush
- system features can be customised for specific purification needs (eg. high or low pressure operation, automated injection, UV, pH, conductivity detection, etc.)



# Preparative LC-Systems

## Bio-Prep Series

The YMC Bio-Prep series of low pressure liquid chromatography systems are designed for purification of proteins and other bio-molecules. Designed for use with ion exchange, affinity, HIC and other modes of chromatography suitable for purification of large molecules, they are suitable for operation at pilot and production scale and are offered in three flow rate ranges with various options for process control and monitoring.

Key features include:

- high performance diaphragm pump enables stable flow rate control with minimal pulsation
- wide variety of operation programs allows flexibility in programming
- built-in security features
- optional data transfer to a PC
- compatible with integrated PC or remote control via PC
- installed module for automatic tracking of required maintenance
- compliant with IQ/OQ validation
- audit log records all system activities
- customised design and fabrication for specific applications available on request

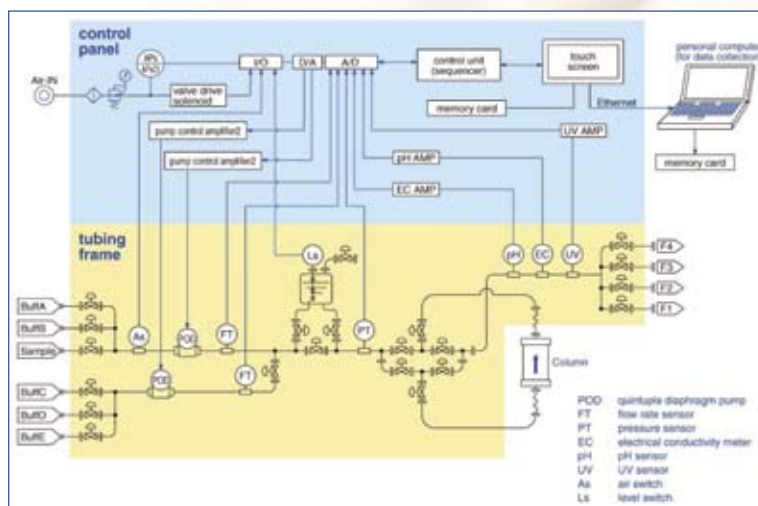

## Standard Specifications

	Type I	Type II	Type III
<b>Pump type</b>	quintuple diaphragm		
<b>Flow rate range (l/h)</b>	~3000 ml/min (~180 l/h)	~8000 ml/min (~480 l/h)	~20000 ml/min (~1200 l/h)
<b>Flow rate accuracy</b>	one hundredth of the range		
<b>Nominal pipe size</b>	8A in 3-A standard	10A in 3-A standard	15A in 3-A standard
<b>Inlet</b>	4 ports		
<b>Outlet</b>	4 ports		
<b>UV sensor</b>	set at 190 - 280 nm arbitrarily		
<b>pH sensor</b>	•	•	•
<b>Electrical conductivity meter</b>	•	•	•
<b>Flow rate meter</b>	•	•	•
<b>Pressure sensor</b>	•	•	•
<b>Bubble trap</b>	•	•	•
<b>Normal pressure</b>	4 bar		
<b>Line pressure limit</b>	6 bar		
<b>Power requirements</b>	three-phase AC 200V		
<b>Utility requirements</b>	compressed air (6 bar)		